

# ACCESS CONTROL



## 1650 LB MODULAR MAGNETIC LOCK 1510 SERIES



1

### DESCRIPTION

The **1510 Series** is an ANSI grade 1 modular magnetic lock with 1650 lb holding force. They are field upgradeable and can be serviced without removing from the door frame. When power is removed the holding force is released.

### FEATURES

- 1650 lb holding force
- Autosensing 12/24 VDC voltage input
- ANSI/BHMA grade 1 compliant
- BHMA certified holding force
- Quick mount assembly



ACCESS CONTROL

SPECIFICATIONS	
<b>Supply Voltage</b>	12/24 VDC
<b>Supply Current</b>	
<b>1511, 1513</b>	350 mA at 24 VDC 670 mA at 12 VDC
<b>1512</b>	700 mA at 24 VDC 1.3 A at 12 VDC
<b>Holding Force</b>	1650 lbs
<b>Dimensions</b>	
<b>1511, 1513</b>	11" L x 2.75" H x 1.56" D (27.9 x 6.9 x 3.9 cm)
<b>1512</b>	22" L x 2-3/4" H x 1.56" D (55.8 x 6.9 x 3.9 cm)
<b>Weight</b>	
<b>1511, 1513</b>	11 lbs (4.9 kg)
<b>1512</b>	26.4 lbs (11.9 kg)
<b>Approvals</b>	UL, CSFM (3774-0324:100), MEA Listed (61-95-E)
<b>Warranty</b>	Lifetime

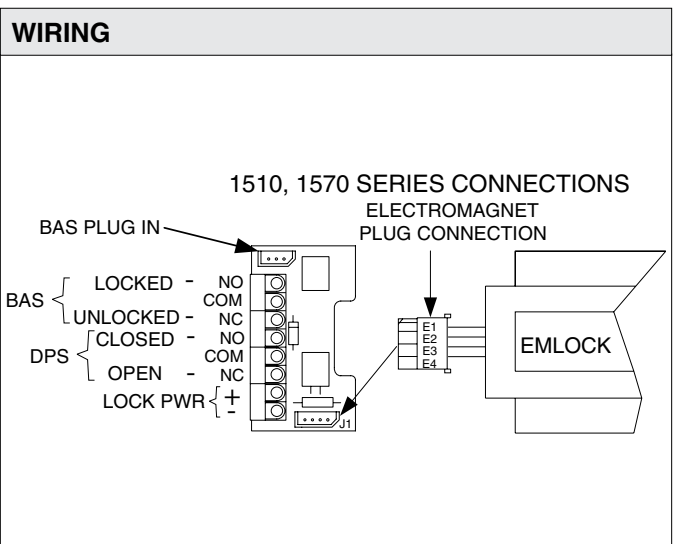

### ORDERING INFORMATION

15	Series Number
11	Magnetic lock, surface mount, single, 1650 lb
12	Magnetic lock, surface mount, double 1650 lb
13	Magnetic lock, surface mount, single, 1650 lb w/ split armature for pair of doors
V	Satin Bronze
X	Oil Rubbed Broze
Y	Bright Chrome